

HYDRAULIC MOTORS MS

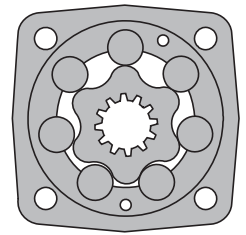

APPLICATION

- » Conveyors
- » Metal working machines
- » Agricultural machines
- » Road building machines
- » Mining machinery
- » Food industries
- » Special vehicles etc.

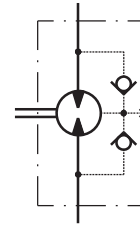

CONTENTS

Specification data	5÷6
Function diagrams	7÷12
Dimensions and mounting	13÷16
Tacho connection	16
Permissible Shaft Seal pressure.....	16
Shaft extensions	17
Motor with Drum brake- MSB	18
Permissible shaft loads	19
Function diagram for MSB	19
Dimensions and mounting- MSS, V, U	20÷23
Internal Spline data	23
Order code	24

OPTIONS

- » Model - Disc valve, roll-gerotor
- » Flange and wheel mount
- » Short motor
- » Motor with Drum Brake
- » Tacho connection
- » Speed sensing
- » Side and rear ports
- » Shafts - straight, splined and tapered
- » SAE, Metric and BSPP ports
- » Other special features

GENERAL

Max. Displacement, cm ³ /rev [in ³ /rev]	564,9 [34.47]
Max. Speed, RPM	1000
Max. Torque, daNm [lb-in]	cont.: 85 [7520] int.: 99 [8760]
Max. Output, kW [HP]	23 [30.8]
Max. Pressure Drop, bar [PSI]	cont.: 210 [3050] int.: 275 [3990]
Max. Oil Flow, lpm [GPM]	90 [24]
Min. Speed, RPM	5
Permissible Shaft Loads, daN [lbs]	P _a =500 [1125]
Pressure fluid	Mineral based- HLP(DIN 51524) or HM(ISO 6743/4)
Temperature range, °C [°F]	-40÷140 [-40÷284]
Optimal Viscosity range, mm ² /s [SUS]	20÷75 [98÷347]
Filtration	ISO code 20/16 (Min. recommended fluid filtration of 25 microns)

Oil flow in drain line

Pressure drop bar [PSI]	Viscosity mm ² /s [SUS]	Oil flow in drain line lpm [GPM]
140 [2030]	20 [98]	1,5 [.396]
	35 [164]	1 [.264]
210 [3045]	20 [98]	3 [.793]
	35 [164]	2 [.528]

Pressure Losses

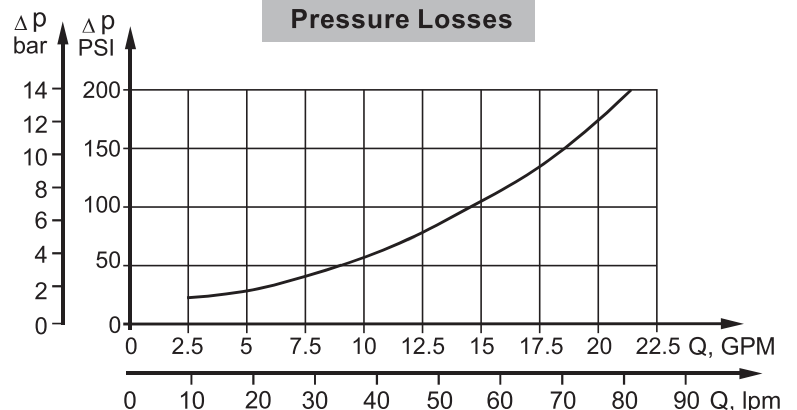

SPECIFICATION DATA

Type		MS 80	MS 100	MS 125	MS 160	MS 200
Displacement, cm³/rev [in³/rev]		80,5 [4.91]	100 [6.1]	125,7 [7.67]	159,7 [9.74]	200 [12.2]
Max. Speed, [RPM]	cont.	810	750	600	470	375
	Int.*	1000	900	720	560	450
Max. Torque daNm [lb-in]	cont.	24 [2120]	30,5 [2700]	37,5 [3320]	49 [4340]	61 [5400]
	Int.*	31 [2740]	39 [3450]	49 [4340]	60 [5310]	72 [6370]
Max. Output kW [HP]	cont.	15,5 [20.8]	18 [24.1]	18 [24.1]	16,5 [22.1]	16,5 [22.1]
	int.*	19,5 [26.2]	22,8 [30.2]	22,5 [30.2]	23 [30.8]	22 [29.52]
Max. Pressure Drop bar [PSI]	cont.	210 [3050]	210 [3050]	210 [3050]	210 [3050]	210 [3050]
	Int.*	275 [3990]	275 [3990]	275 [3990]	275 [3990]	275 [3990]
	peak**	295 [4280]	295 [4280]	295 [4280]	295 [4280]	295 [4280]
Max. Oil Flow lpm [GPM]	cont.	65 [17]	75 [20]	75 [20]	75 [20]	75 [20]
	Int.*	80 [21]	90 [24]	90 [24]	90 [24]	90 [24]
Max. Inlet Pressure bar [PSI]	cont.	230 [3340]	230 [3340]	230 [3340]	230 [3340]	230 [3340]
	Int.*	295 [4280]	295 [4280]	295 [4280]	295 [4280]	295 [4280]
	peak**	300 [4350]	300 [4350]	300 [4350]	300 [4350]	300 [4350]
Max. Return Pressure with Drain Line bar [PSI]	cont.	140 [2030]	140 [2030]	140 [2030]	140 [2030]	140 [2030]
	Int.*	175 [2540]	175 [2540]	175 [2540]	175 [2540]	175 [2540]
	peak**	210 [3050]	210 [3050]	210 [3050]	210 [3050]	210 [3050]
Max. Starting Pressure with Unloaded Shaft, bar [PSI]		12 [175]	10 [145]	10 [145]	8 [115]	8 [115]
Min. Starting Torque daNm [lb-in]	at max. press. drop cont.	18 [1590]	23 [2040]	29 [2570]	37 [3270]	47 [4160]
	at max. press. drop Int.*	23,5 [2080]	30 [2660]	38 [3360]	46 [4070]	56 [4960]
Min. Speed***, [RPM]		10	10	8	8	6
Weight, kg [lb] For Rear Ports + 0,40 [.88]	MS(F)	9,9 [21.8]	10,1 [22.2]	10,4 [22.9]	10,8 [23.8]	11,2 [24.7]
	MSW	10,4 [22.9]	10,6 [23.3]	10,9 [24]	11,3 [24.6]	11,7 [25.8]
	MSS	7,9 [17.4]	8,1 [17.8]	8,4 [18.5]	8,8 [19.4]	9,2 [20.2]
	MSV	5,8 [12.8]	6 [13.2]	6,3 [13.9]	6,7 [14.8]	7,1 [15.6]
	MSQ	10,3 [22.7]	10,5 [23.2]	10,8 [23.8]	11,2 [24.7]	11,6 [25.6]
	MSB	16,9 [37.3]	17,1 [37.7]	17,4 [38.3]	17,8 [39.2]	18,2 [41.1]

* Intermittent operation: the permissible values may occur for max. 10% of every minute.

** Peak load: the permissible values may occur for max. 1% of every minute.

*** For speeds lower than given, consult factory or your regional manager.

1. Intermittent speed and intermittent pressure must not occur simultaneously.
2. Recommended filtration is per ISO cleanliness code 20/16. A nominal filtration of 25 micron or better.
3. Recommend using a premium quality, anti-wear type mineral based hydraulic oil HLP(DIN51524) or HM (ISO 6743/4).
If using synthetic fluids consult the factory for alternative seal materials.
4. Recommended minimum oil viscosity 13 mm²/s [70 SUS] at 50°C [122°F].
5. Recommended maximum system operating temperature is 82°C [180°F].
6. To assure optimum motor life fill with fluid prior to loading and run at moderate load and speed for 10-15 minutes.

SPECIFICATION DATA (continued)

Type		MS 250	MS 315	MS 400	MS 475	MS 525	MS 565
Displacement, cm³/rev [in³/rev]		250 [15.3]	314,9 [19.2]	397 [24.2]	474,6[28.96]	522,7 [31.88]	564,9[34.47]
Max. Speed, [RPM]	cont.	300	240	190	160	145	130
	Int.*	360	290	230	190	175	160
Max. Torque daNm [lb-in]	cont.	72 [6370]	82,5 [7300]	86,5 [7660]	85 [7520]	85 [7520]	85 [7520]
	Int.*	87 [7700]	100 [8850]	99 [8760]	99 [8760]	99 [8760]	99 [8760]
Max. Output kW [HP]	cont.	14,5 [19.4]	15 [20.1]	11 [14.8]	8,4 [11]	7,6 [10.2]	6,9 [9]
	int.*	18 [24.1]	17 [22.8]	12,5 [16.8]	11,3 [15]	10,4 [13.9]	9,6 [13]
Max. Pressure Drop bar [PSI]	cont.	200 [2900]	200 [2900]	160 [2320]	130 [1880]	115 [1670]	105 [1520]
	Int.*	250 [3630]	240 [3480]	190 [2760]	150 [2180]	135 [1960]	125 [1810]
	peak**	270 [3920]	260 [3770]	210 [3050]	170 [2470]	155 [2250]	145 [2100]
Max. Oil Flow lpm [GPM]	cont.	75 [20]	75 [20]	75 [20]	75 [20]	75 [20]	75 [20]
	Int.*	90 [24]	90 [24]	90 [24]	90 [24]	90 [24]	90 [24]
Max. Inlet Pressure bar [PSI]	cont.	230 [3340]	230 [3340]	230 [3340]	230 [3340]	230 [3340]	230 [3340]
	Int.*	295 [4280]	295 [4280]	295 [4280]	295 [4280]	295 [4280]	295 [4280]
	peak**	300 [4350]	300 [4350]	300 [4350]	300 [4350]	300 [4350]	300 [4350]
Max. Return Pressure with Drain Line bar [PSI]	cont.	140 [2030]	140 [2030]	140 [2030]	140 [2030]	140 [2030]	140 [2030]
	Int.*	175 [2540]	175 [2540]	175 [2540]	175 [2540]	175 [2540]	175 [2540]
	peak**	210 [3050]	210 [3050]	210 [3050]	210 [3050]	210 [3050]	210 [3050]
Max. Starting Pressure with Unloaded Shaft, bar [PSI]		8 [115]	8 [115]	8 [115]	8 [115]	8 [115]	8 [115]
Min. Starting Torque daNm [lb-in]	at max. press. drop cont.	56 [4960]	71 [6280]	71 [6280]	71 [6280]	71 [6280]	71 [6280]
	at max. press. drop Int.*	70 [6200]	85 [7520]	84 [7430]	84 [7430]	84 [7430]	84 [7430]
Min. Speed***, [RPM]		6	5	5	5	5	5
Weight, kg [lb] For Rear Ports + 0,40 [.88]	MS(F)	11,7 [25.8]	12,4 [27.3]	13,1 [29.3]	14,1 [31]	14,6 [32.2]	15 [33.1]
	MSW	12,2 [26.9]	12,9 [28.4]	13,8 [30.4]	14,6 [32.2]	15,1 [33.3]	15,5 [34.1]
	MSS	9,7 [21.4]	10,4 [22.9]	11,3 [24.9]	12,1 [26.7]	12,6 [27.8]	13 [28.6]
	MSV	7,6 [16.7]	8,3 [18.3]	9,2 [20.2]	10 [22]	10,5 [23.1]	10,9 [24]
	MSQ	12,1 [26.7]	12,8 [28.2]	13,7 [30.2]	14,5 [32]	15 [33.1]	15,4 [33.9]
	MSB	18,7 [41.2]	19,4 [42.7]	20,3 [44.7]	21,1 [46.5]	21,6 [47.6]	23 [48.5]

* Intermittent operation: the permissible values may occur for max. 10% of every minute.

** Peak load: the permissible values may occur for max. 1% of every minute.

*** For speeds lower than given, consult factory or your regional manager.

1. Intermittent speed and intermittent pressure must not occur simultaneously.
2. Recommended filtration is per ISO cleanliness code 20/16. A nominal filtration of 25 micron or better.
3. Recommend using a premium quality, anti-wear type mineral based hydraulic oil HLP(DIN51524) or HM (ISO 6743/4).
If using synthetic fluids consult the factory for alternative seal materials.
4. Recommended minimum oil viscosity 13 mm²/s [70 SUS] at 50°C [122°F].
5. Recommended maximum system operating temperature is 82°C [180°F].
6. To assure optimum motor life fill with fluid prior to loading and run at moderate load and speed for 10-15 minutes.

FUNCTION DIAGRAMS

MS 80

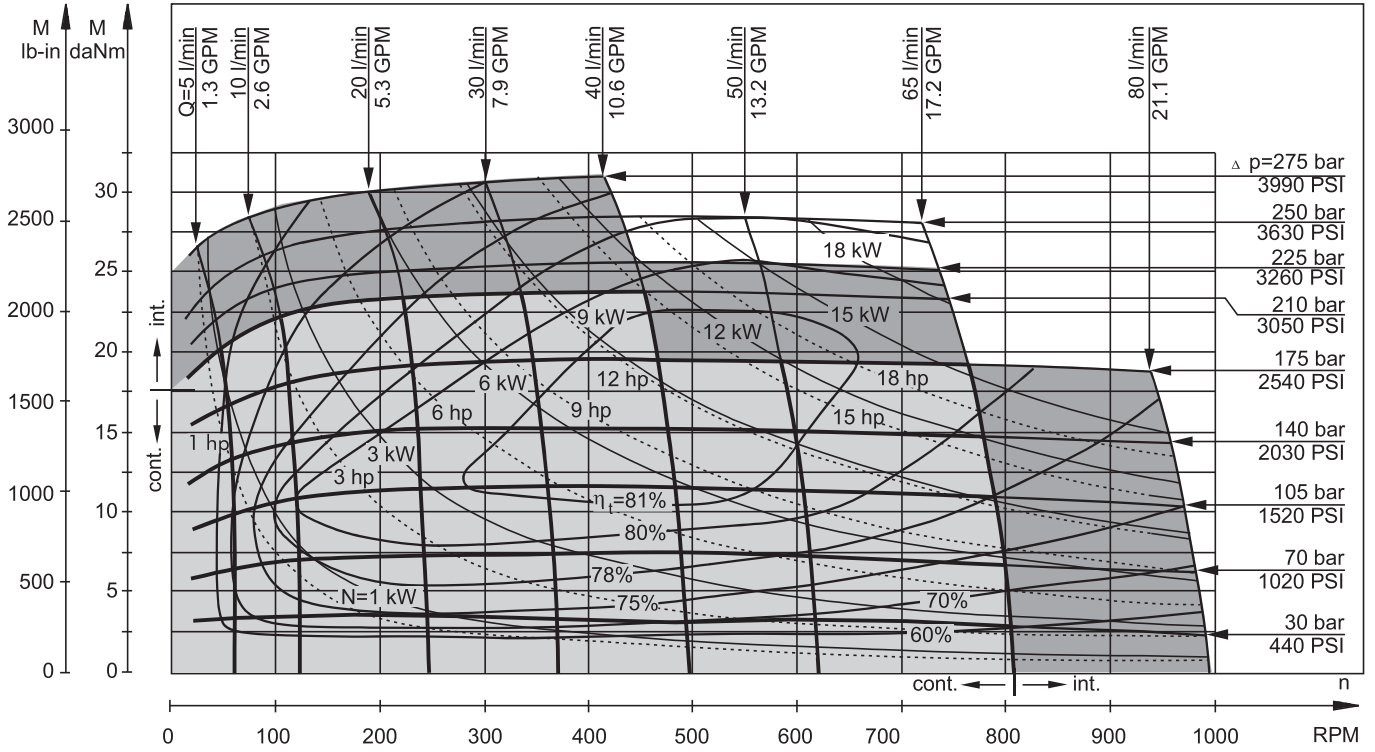

MS 100

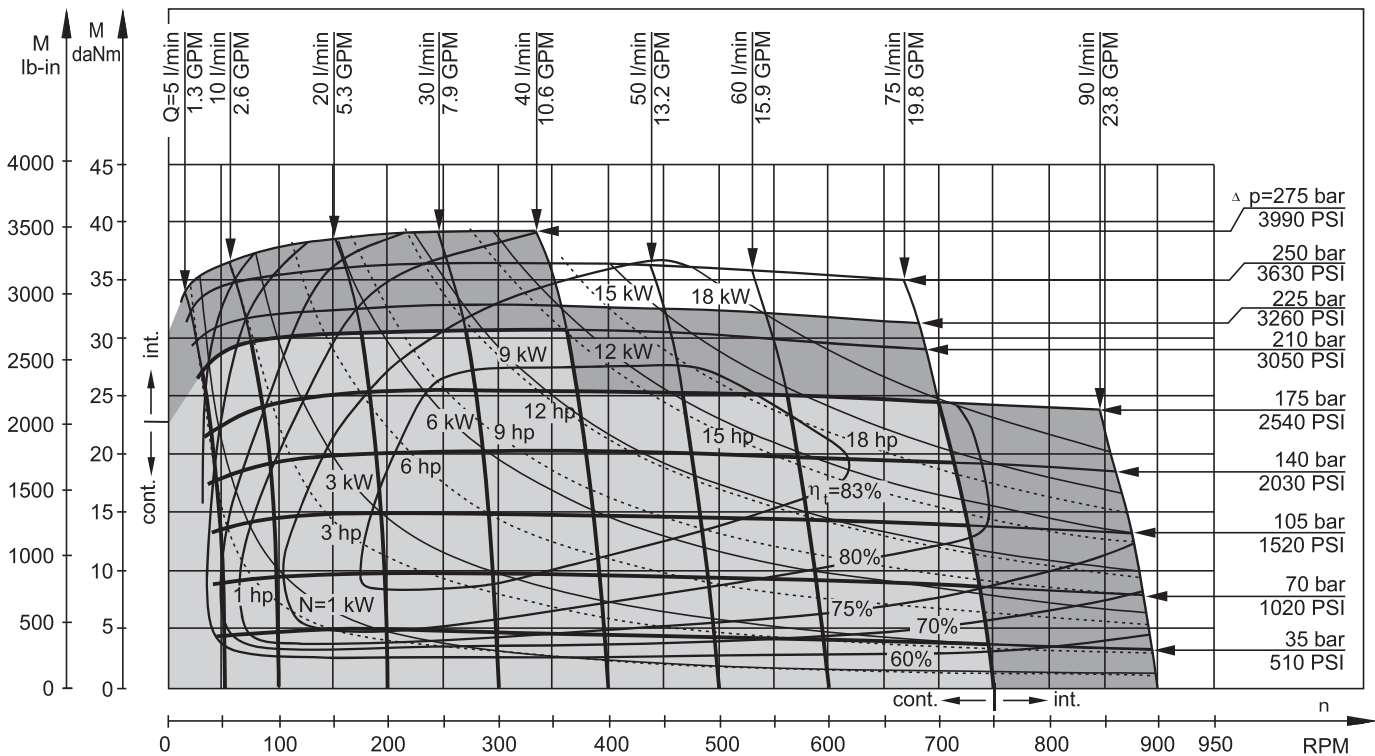

The function diagrams data is for average performance of randomly selected motors at back pressure 5÷10 bar [72.5÷145 PSI] and oil with viscosity of 32 mm²/s [150 SUS] at 50°C [122°F].

FUNCTION DIAGRAMS

MS 125

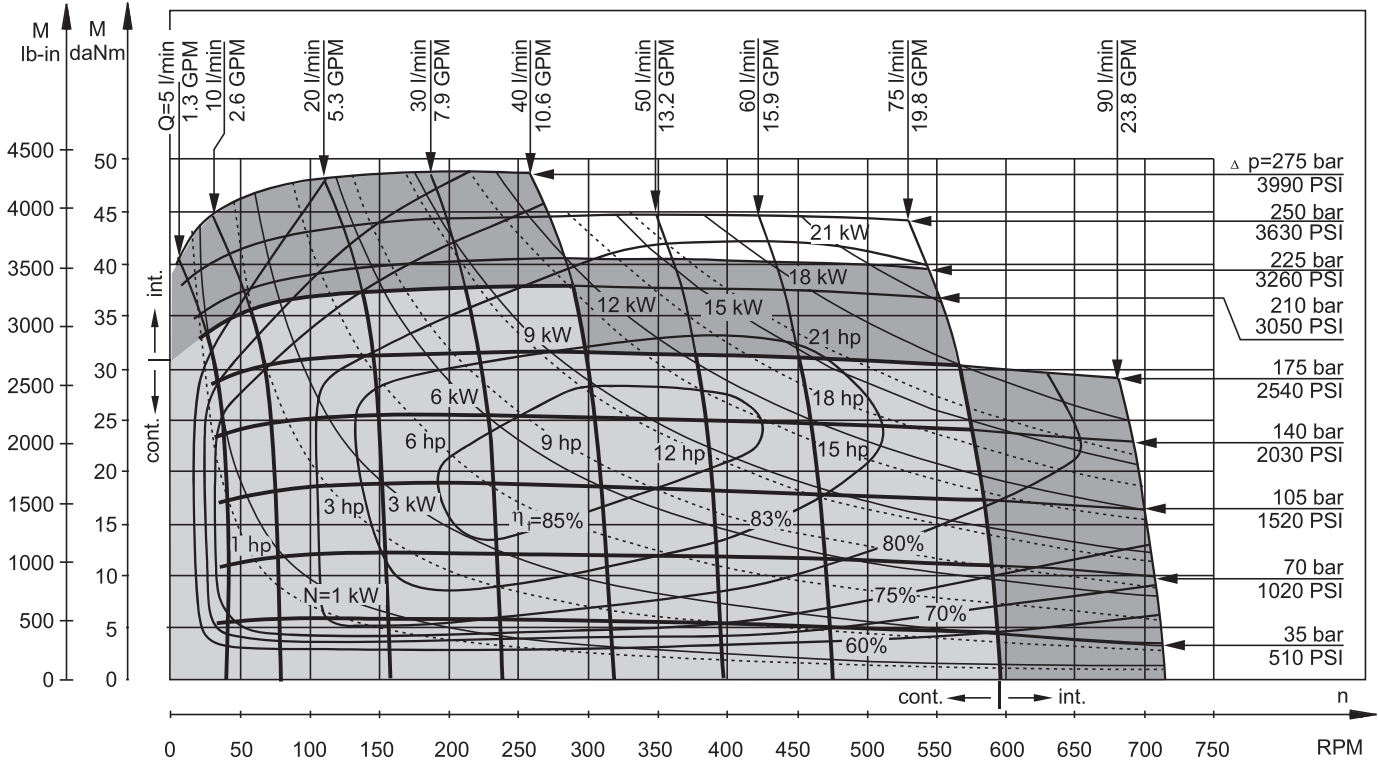

MS 160

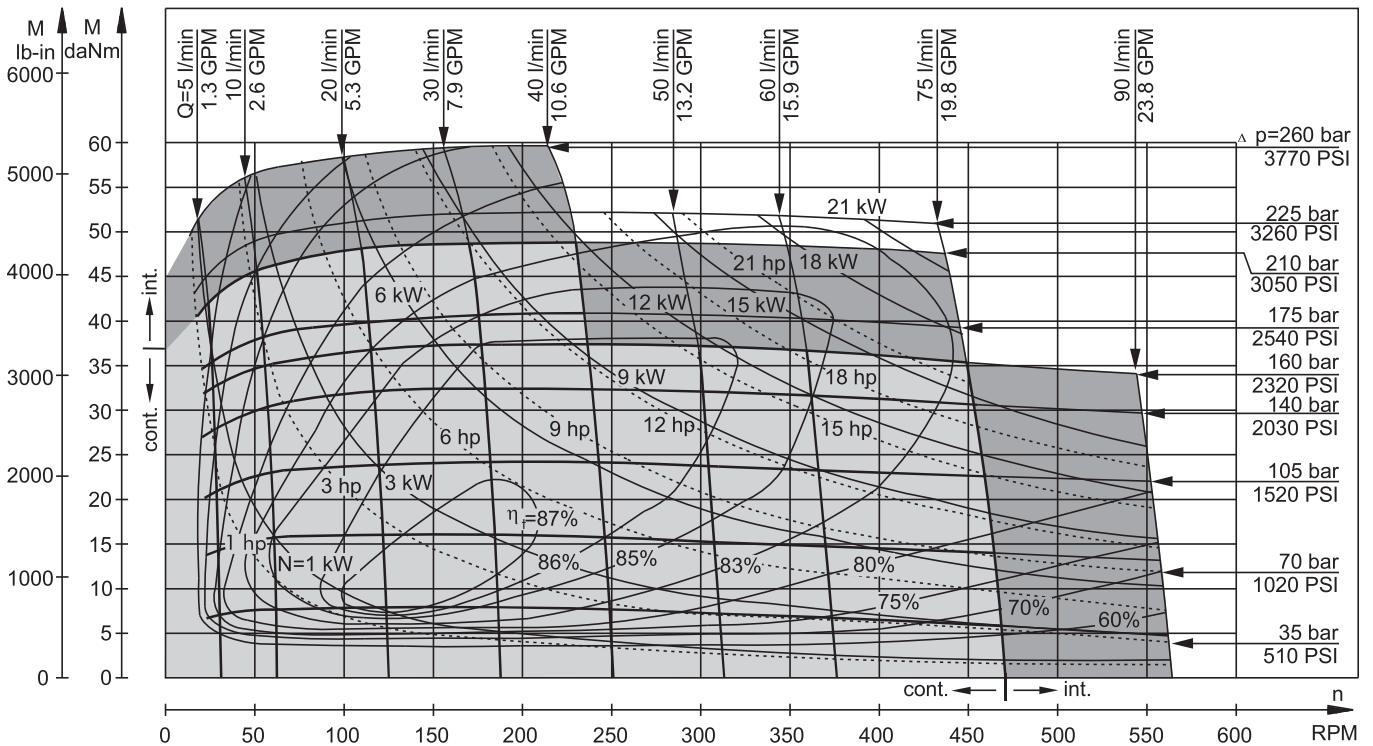

The function diagrams data is for average performance of randomly selected motors at back pressure 5÷10 bar [72.5÷145 PSI] and oil with viscosity of 32 mm²/s [150 SUS] at 50°C [122°F].

FUNCTION DIAGRAMS

MS 200

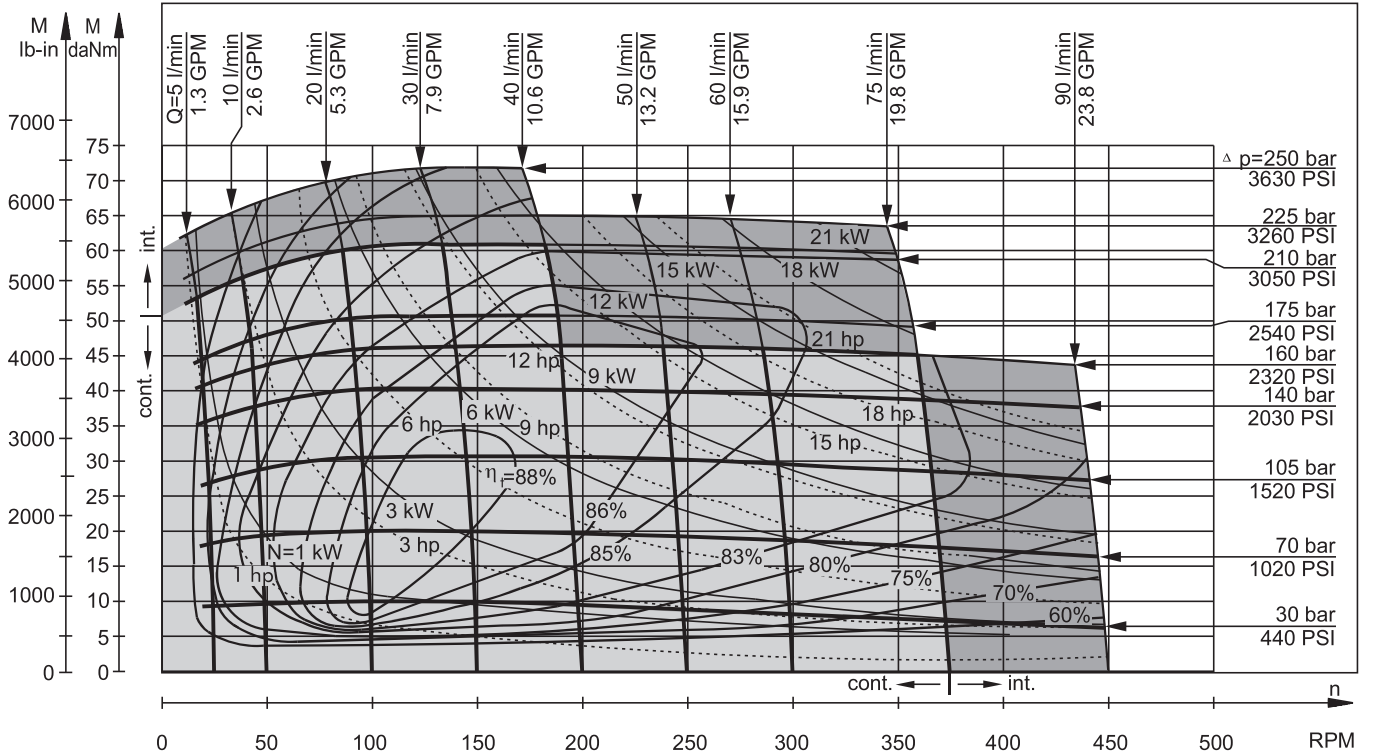

MS 250

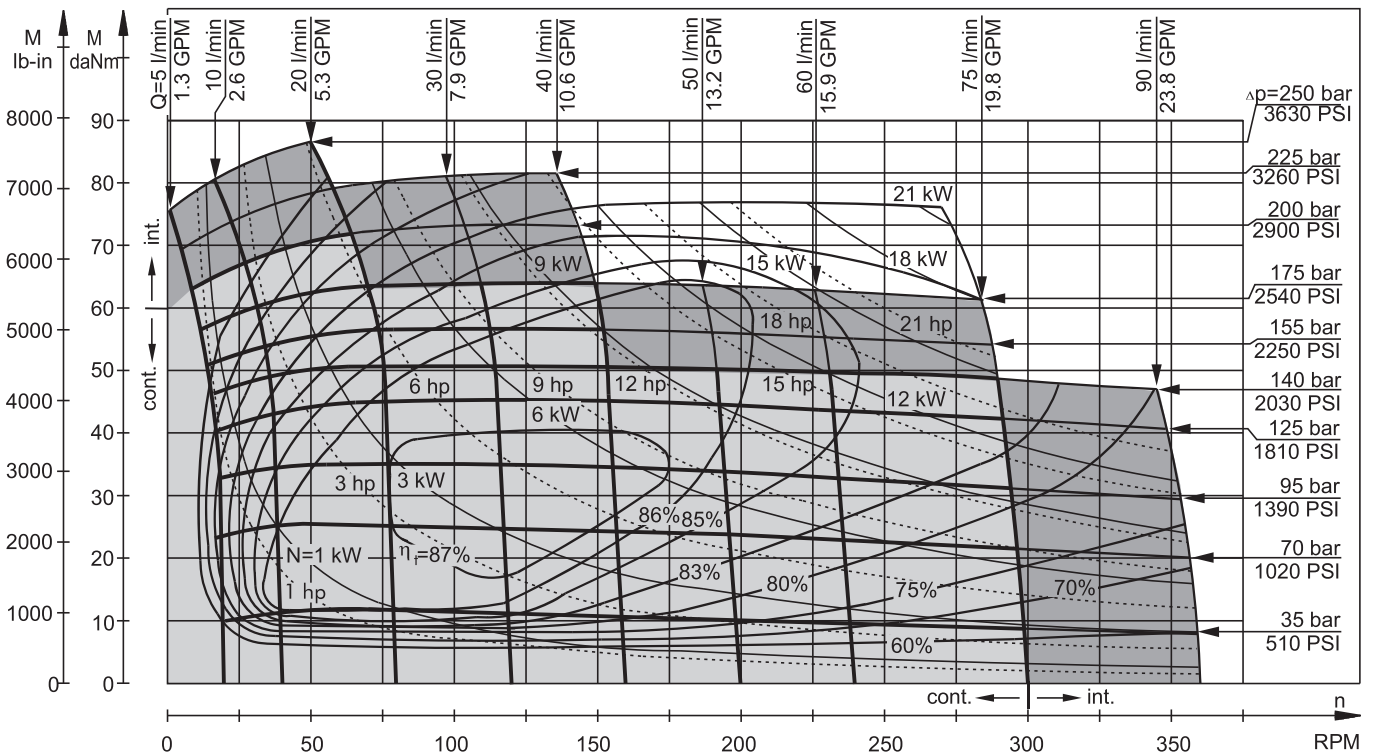

The function diagrams data is for average performance of randomly selected motors at back pressure 5÷10 bar [72.5÷145 PSI] and oil with viscosity of 32 mm²/s [150 SUS] at 50°C [122°F].

FUNCTION DIAGRAMS

MS 315

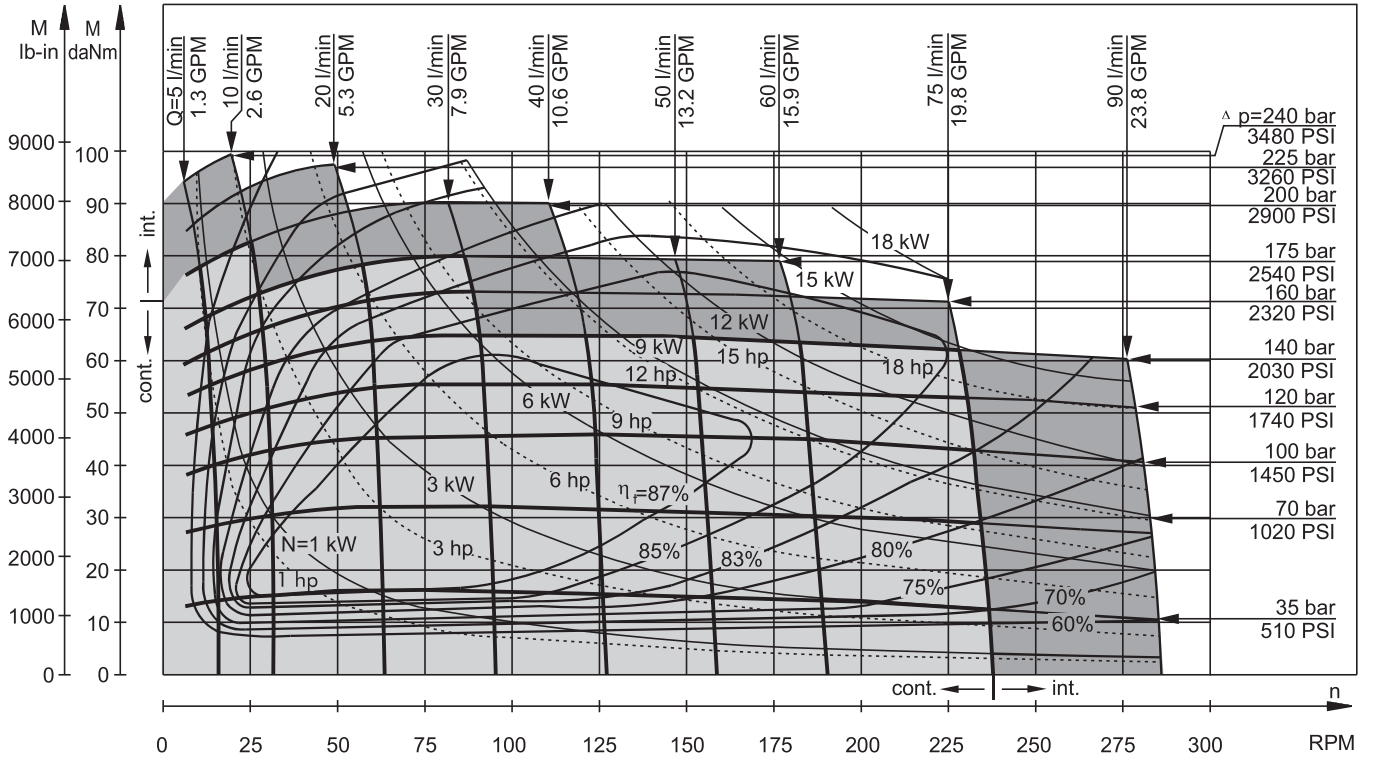

MS 400

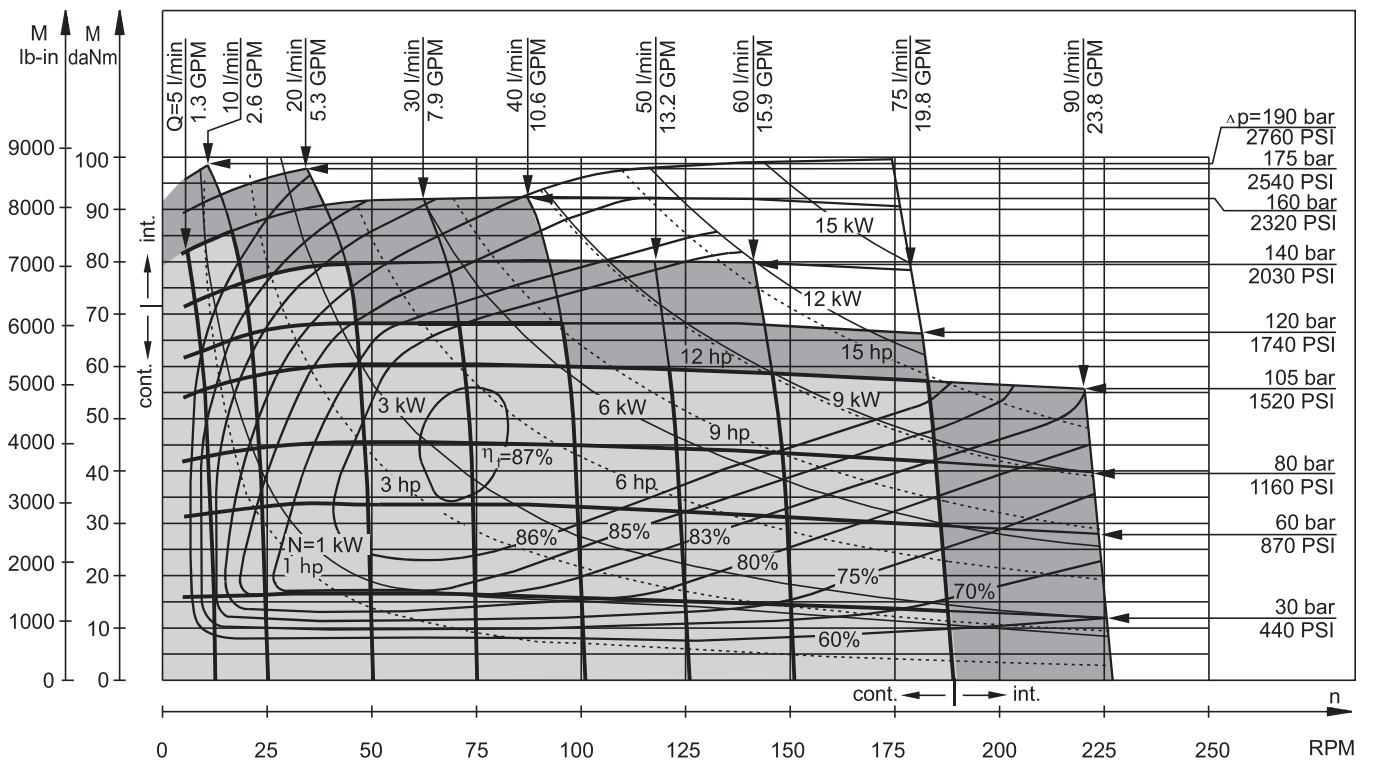

The function diagrams data is for average performance of randomly selected motors at back pressure 5 ÷ 10 bar [72.5 ÷ 145 PSI] and oil with viscosity of 32 mm²/s [150 SUS] at 50°C [122°F].

FUNCTION DIAGRAMS

MS 475

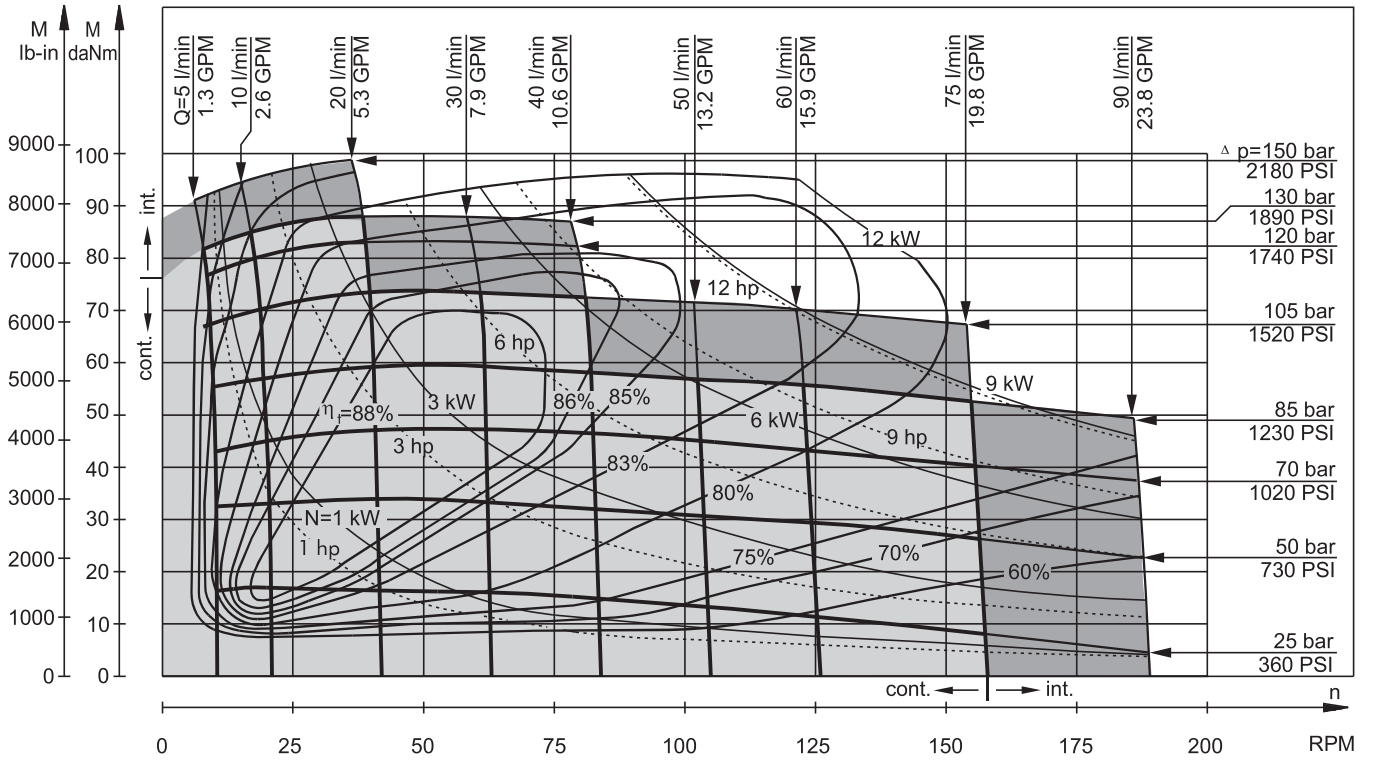

MS 525

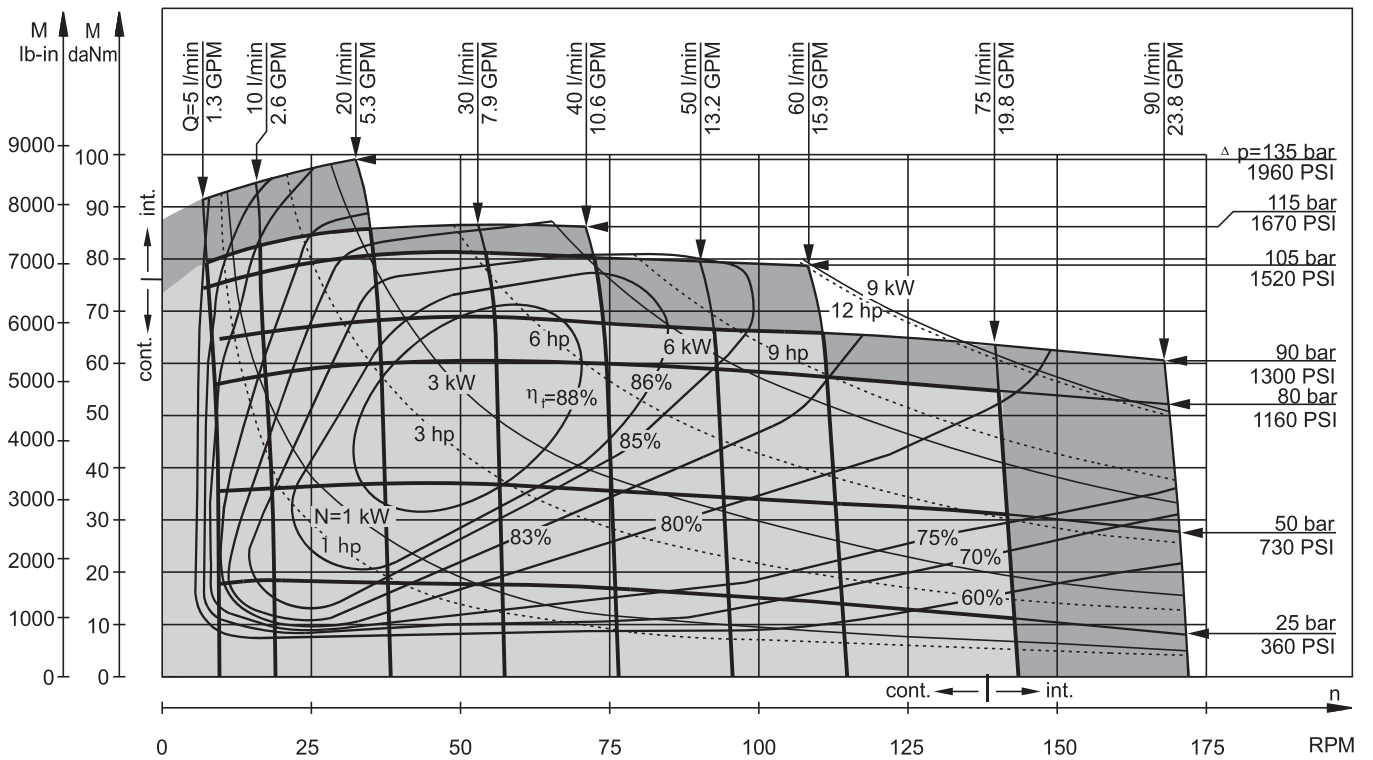

The function diagrams data is for average performance of randomly selected motors at back pressure 5÷10 bar [72.5÷145 PSI] and oil with viscosity of 32 mm²/s [150 SUS] at 50°C [122°F].

FUNCTION DIAGRAMS

MS 565

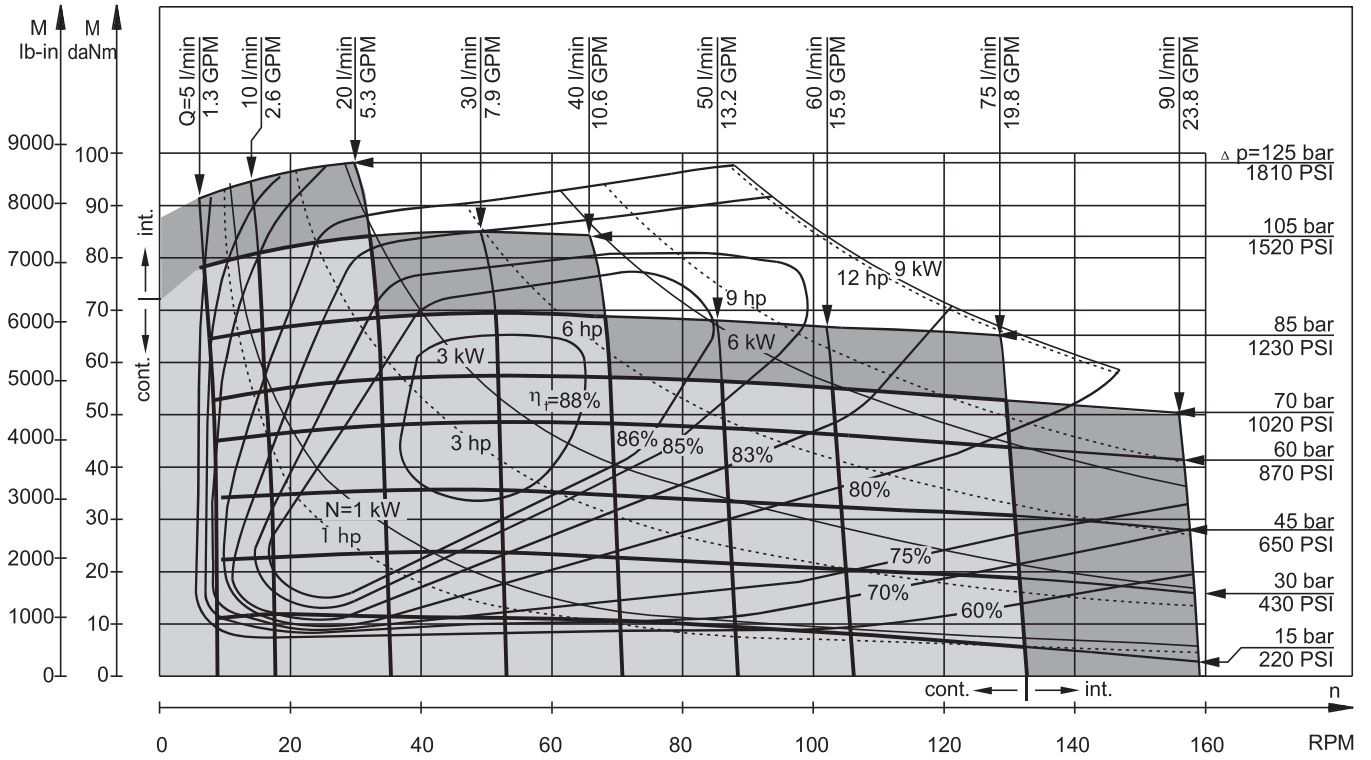

The function diagrams data is for average performance of randomly selected motors at back pressure 5÷10 bar [72.5÷145 PSI] and oil with viscosity of 32 mm²/s [150 SUS] at 50°C [122°F].

**DIMENSIONS AND MOUNTING DATA
MS, MSF, MSA, MSW**

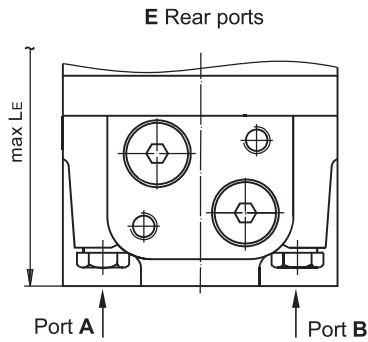
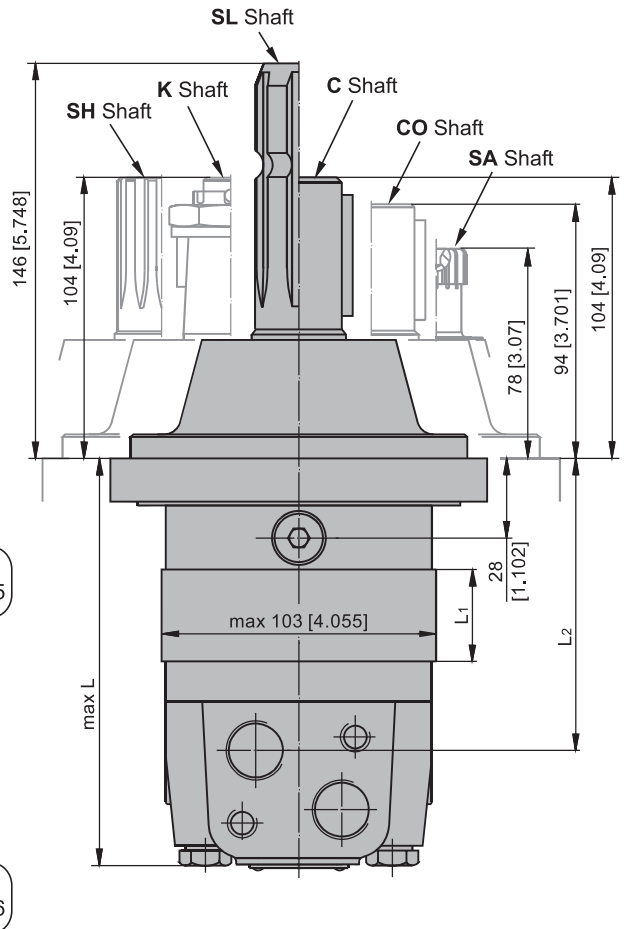
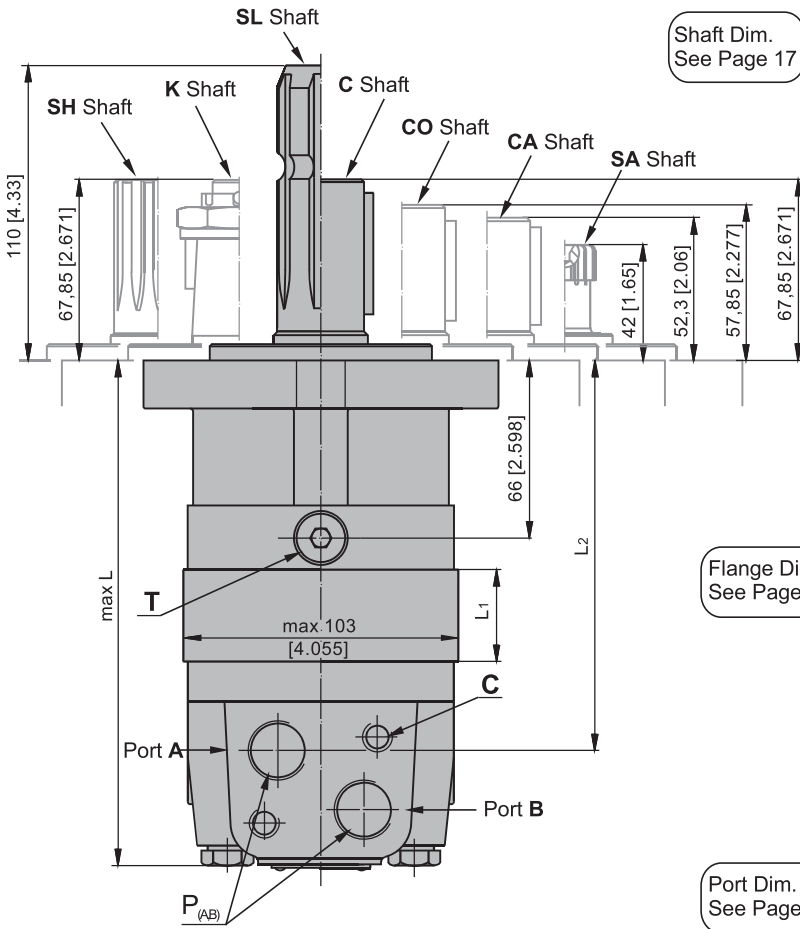

- C** : 2xM10-12 mm [.47 in] depth
- P_(A,B)**: 2xG1/2 or 2xM22x1,5-15 mm [.59 in] depth
- T** : G ¼ or M14x1,5- 12 mm [.47 in] depth (plugged)

Standard Rotation
Viewed from Shaft End
Port **A** Pressurized - **CW**
Port **B** Pressurized - **CCW**

Reverse Rotation
Viewed from Shaft End
Port **A** Pressurized - **CCW**
Port **B** Pressurized - **CW**

Type	L, mm [in]	L ₂ , mm [in]	*L _E , mm [in]	Type	L, mm [in]	L ₂ , mm [in]	*L _E , mm [in]	L ₁ , mm [in]
MS(F, A) 80	168 [6.61]	124 [4.88]	173 [6.81]	MSW 80	129 [5.08]	87 [3.43]	138 [5.43]	14,0 [.55]
MS(F, A) 100	171 [6.73]	128 [5.04]	177 [6.97]	MSW100	133 [5.23]	91 [3.58]	142 [5.59]	17,4 [.69]
MS(F, A) 125	176 [6.93]	132 [5.20]	181 [7.13]	MSW 125	137 [5.39]	95 [3.74]	146 [5.75]	21,8 [.86]
MS(F, A) 160	182 [7.17]	138 [5.43]	187 [7.36]	MSW 160	143 [5.63]	101 [3.98]	152 [5.99]	27,8 [1.09]
MS(F, A) 200	189 [7.44]	145 [5.71]	194 [7.64]	MSW 200	150 [5.91]	108 [4.25]	159 [6.26]	34,8 [1.37]
MS(F, A) 250	197 [7.76]	154 [6.06]	203 [7.99]	MSW 250	159 [6.26]	117 [4.61]	168 [6.62]	43,5 [1.71]
MS(F, A) 315	209 [8.23]	165 [6.50]	214 [8.43]	MSW 315	170 [6.69]	128 [5.04]	179 [7.05]	54,8 [2.16]
MS(F, A) 400	223 [8.78]	179 [7.05]	228 [8.98]	MSW 400	184 [7.24]	143 [5.63]	194 [7.64]	69,4 [2.73]
MS(F, A) 475	237 [9.33]	193 [7.60]	242 [9.53]	MSW 475	198 [7.79]	156 [6.14]	207 [8.15]	82,6 [3.25]
MS(F, A) 525	229 [9.02]	185 [7.28]	234 [9.21]	MSW 525	190 [7.48]	148 [5.83]	199 [7.84]	74,5 [2.93]
MS(F, A) 565	235 [9.25]	191 [7.52]	240 [9.45]	MSW 565	196 [7.72]	154 [6.06]	205 [8.07]	80,2 [3.16]

* - For Rear Ported Motors.

DIMENSIONS AND MOUNTING DATA - MSQ

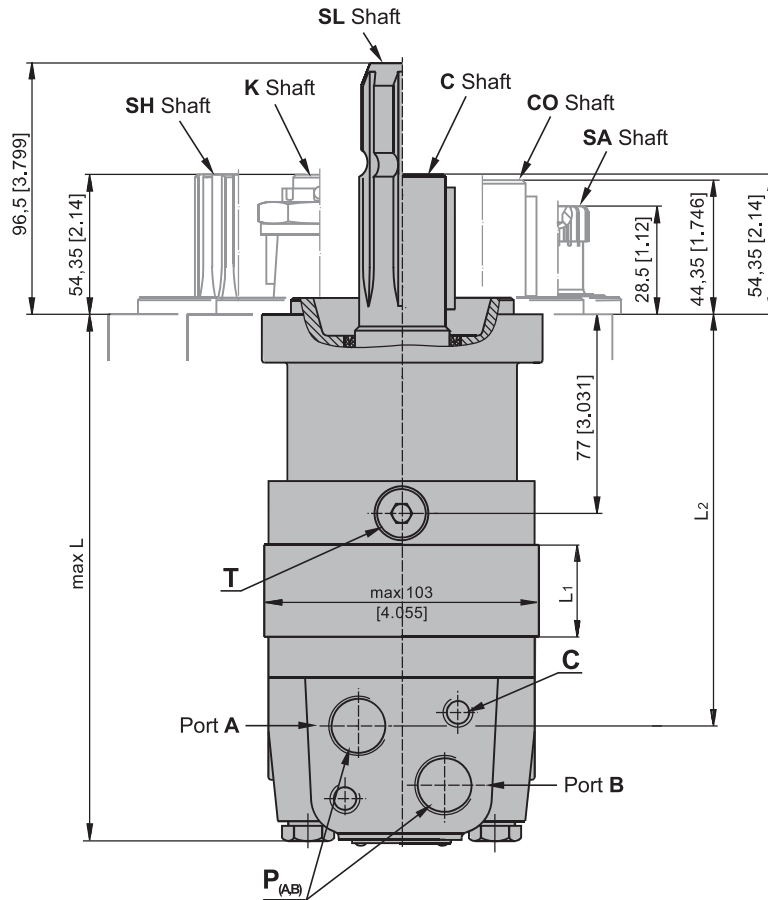

Shaft Dim.
See Page 17

Port Dim.
See Page 16

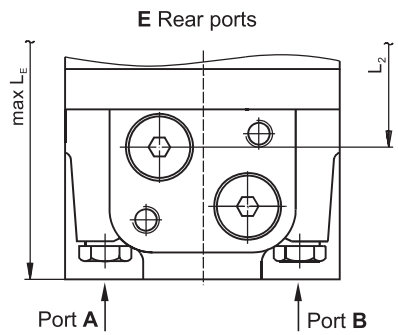

- C** : 2xM10-12 mm [.47 in] depth
- P_(A,B)** : 2xG1/2 or 2xM22x1,5-15 mm [.59 in] depth
- T** : G ¼ or M14x1,5- 12 mm [.47 in] depth (plugged)

Standard Rotation
Viewed from Shaft End
Port A Pressurized - **CW**
Port B Pressurized - **CCW**

Reverse Rotation
Viewed from Shaft End
Port A Pressurized - **CCW**
Port B Pressurized - **CW**

Type	L, mm [in]	L ₂ , mm [in]	*L _E , mm [in]	L ₁ , mm [in]
MSQ 80	179 [7.05]	136 [5.35]	185 [7.28]	14,0 [.55]
MSQ 100	183 [7.21]	140 [5.51]	189 [7.44]	17,4 [.69]
MSQ 125	187 [7.36]	144 [5.67]	193 [7.60]	21,8 [.86]
MSQ 160	193 [7.60]	150 [5.91]	199 [7.83]	27,8 [1.09]
MSQ 200	200 [7.87]	157 [6.18]	206 [8.11]	34,8 [1.37]
MSQ 250	209 [8.23]	166 [6.54]	215 [8.46]	43,5 [1.71]
MSQ 315	220 [8.66]	177 [6.67]	226 [8.90]	54,8 [2.16]
MSQ 400	235 [9.25]	192 [7.56]	241 [9.49]	69,4 [2.73]
MSQ 475	247 [9.72]	205 [8.07]	254 [10.0]	82,6 [3.25]
MSQ 525	240 [9.45]	197 [7.76]	246 [9.69]	74,5 [2.93]
MSQ 565	246 [9.69]	203 [7.99]	252 [9.92]	80,2 [3.16]

* - For Rear Ported Motors.

MOUNTING

SAE A-4 Mount (4 Holes)

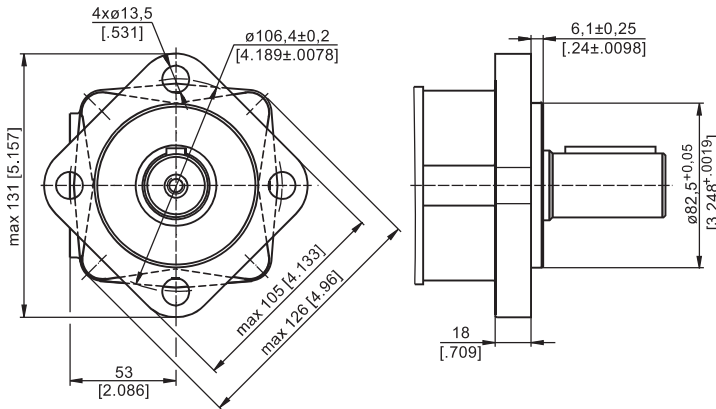

A SAE A-2 Mount (2 Holes)

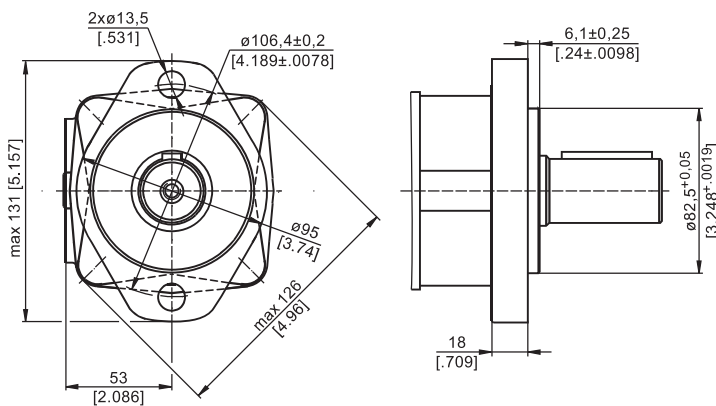

F Magneto Mount (4 Holes)

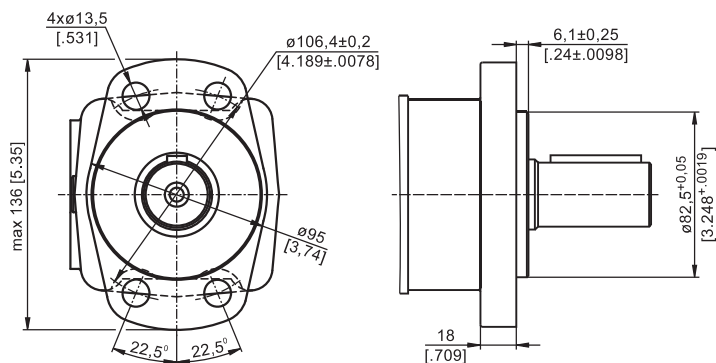

Q Square Mount (4 Holes)

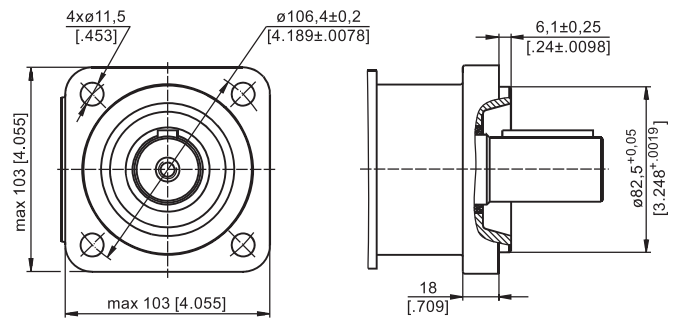

W Wheel Mount

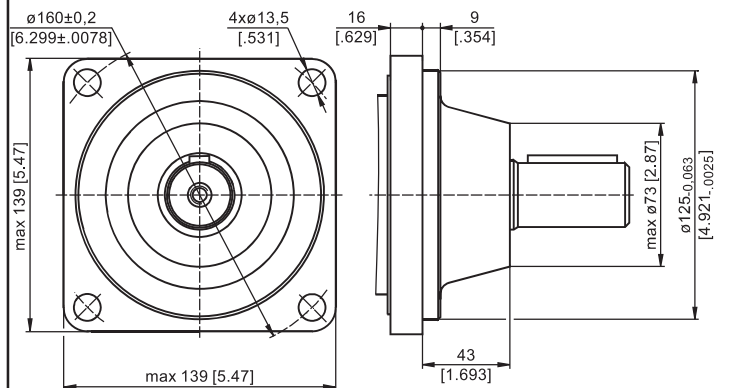

PORTS

Side Ports

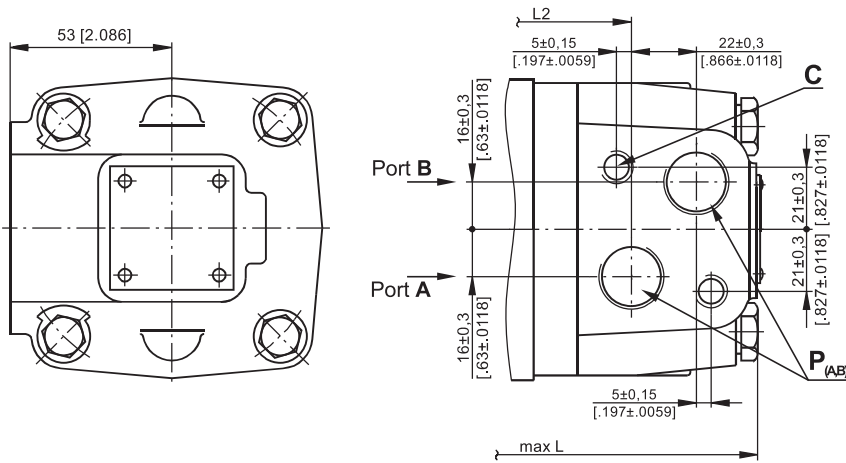

E Rear Ports

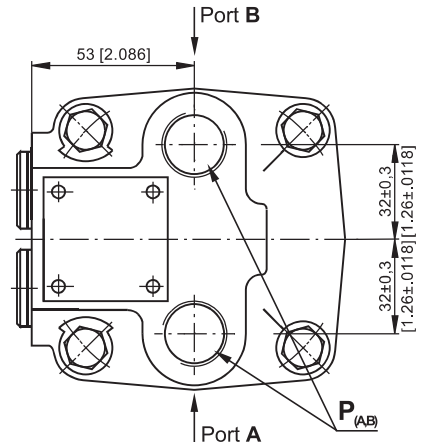

Standard Rotation
Viewed from Shaft End
Port A Pressurized - **CW**
Port B Pressurized - **CCW**

Reverse Rotation
Viewed from Shaft End
Port A Pressurized - **CCW**
Port B Pressurized - **CW**

C : 2xM10-12 mm [.47 in] depth
P_(A,B) : 2xG1/2 or 2xM22x1,5-15 mm [.59 in] depth
T : G ¼ or M14x1,5- 12 mm [.47 in] depth (plugged)

MOTORS WITH TACHO CONNECTION

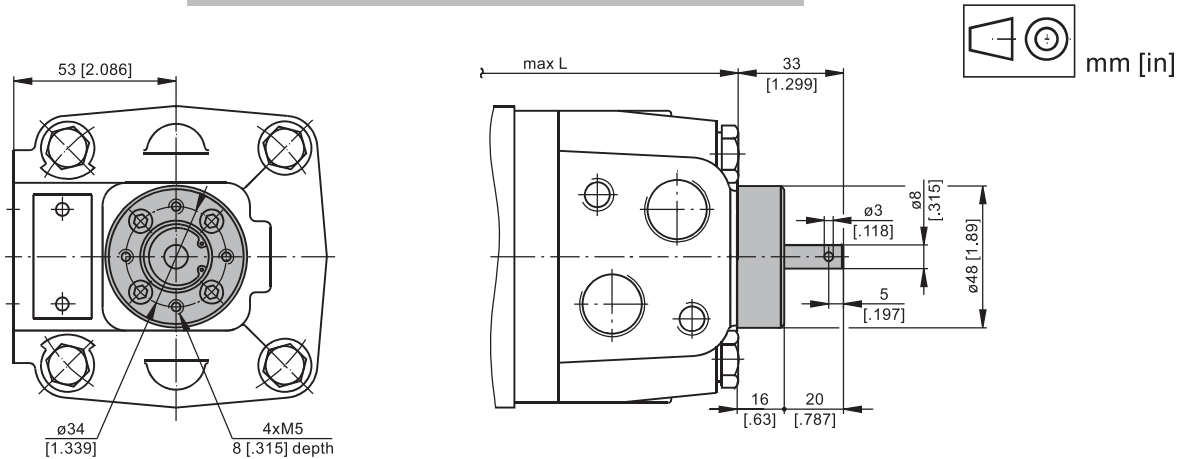

MAX. PERMISSIBLE SHAFT SEAL PRESSURE

Max. return pressure without drain line or
max. pressure in the drain line

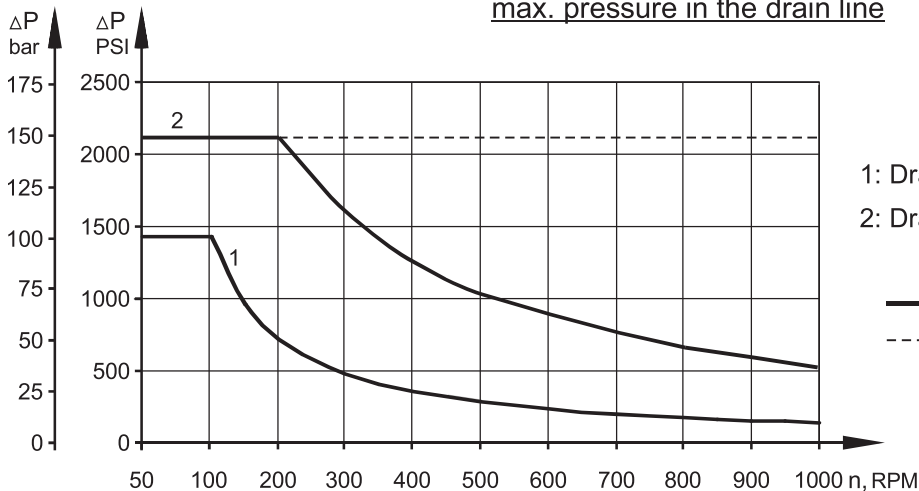

1: Drawing for Standard Shaft Seal
2: Drawing for High Pressure Seal ("U" Seal)
— - continuous operations
- - - - intermittent operations

SHAFT EXTENSIONS

C - $\varnothing 32$ straight, Parallel key A10x8x45 DIN 6885
Max. Torque 77 daNm [6815 lb-in]

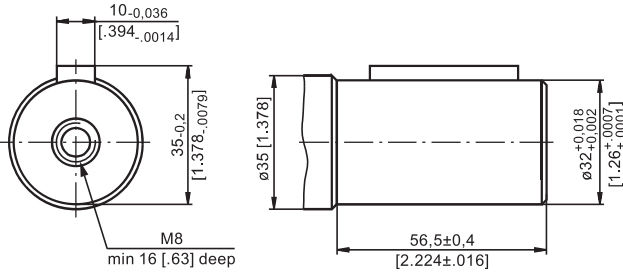

K - tapered 1:10, Parallel key B6x6x20 DIN 6885
Max. Torque 95 daNm [8400 lb-in]

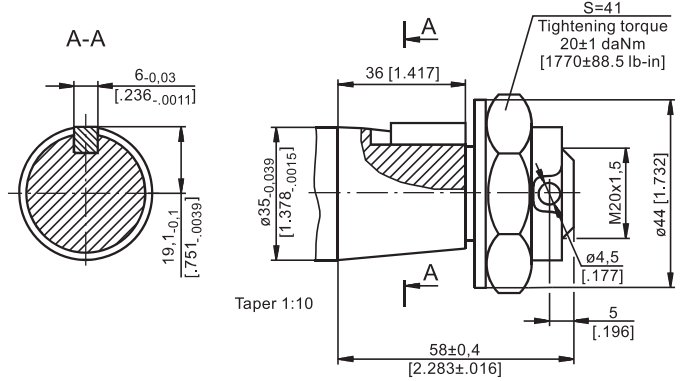

CO - $\varnothing 1\frac{1}{4}$ " straight, Parallel key $\frac{5}{16}$ "x $\frac{5}{16}$ "x $1\frac{1}{4}$ "BS46
Max. Torque 77 daNm [6815 lb-in]

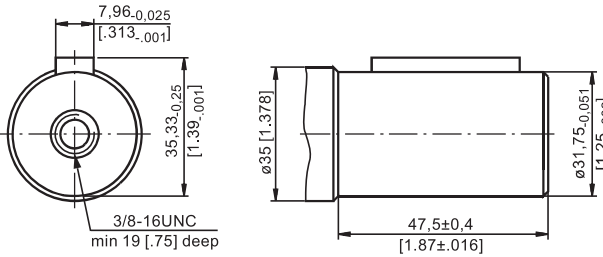

SH - $\varnothing 1\frac{1}{4}$ " splined 14T, DP12/24 ANS B92.1-1970
Max. Torque 95 daNm [8400 lb-in]

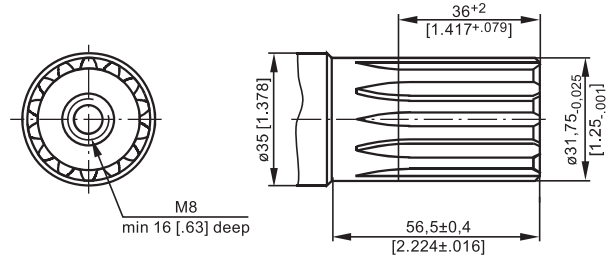

SL - $\varnothing 34,85$ p.t.o. DIN 9611 Form 1
Max. Torque 77 daNm [6815 lb-in]

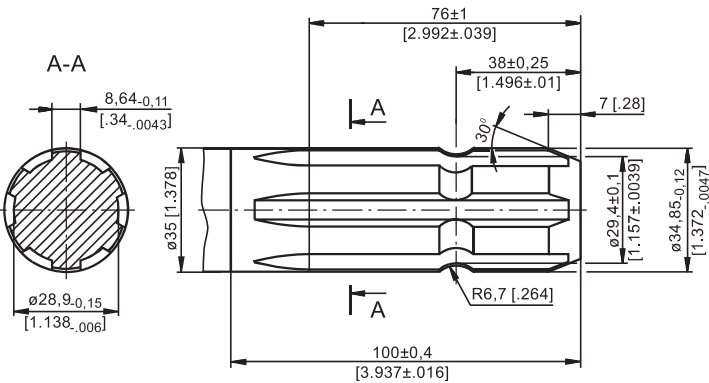

SA - 7/8"-13T splined DP16/32 ANS B92.1-1970
Max. Torque 20 daNm [1770 lb-in]

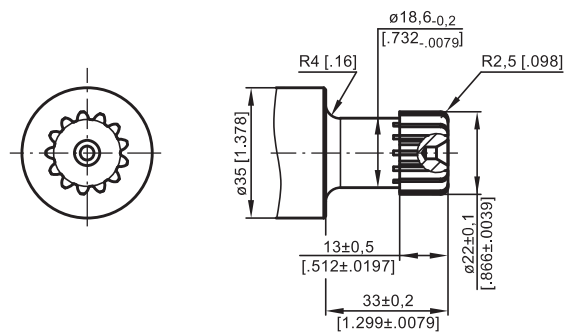

CA - $\varnothing 25$ straight, Parallel key A8x7x32 DIN 6885
Max. Torque 34 daNm [3010 lb-in]

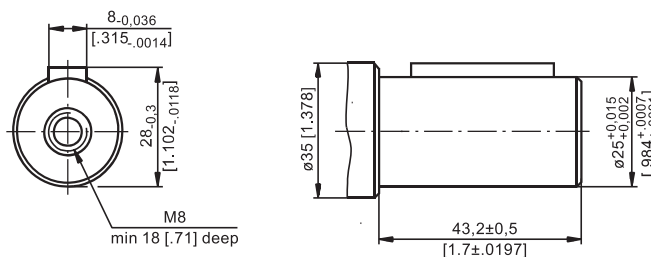

PERMISSIBLE SHAFT LOADS

The output shaft runs in tapered bearings that permit high axial and radial forces. The permissible radial load on the shaft is shown for an axial load of 0 N as function of the distance from the mounting flange to the point of load application. The curves apply to a B10 bearing life of 2000 hours at 100 RPM.

Curve "1" shows max. radial shaft load. Any shaft load exceeding the values shown by the curve will seriously reduce motor life.

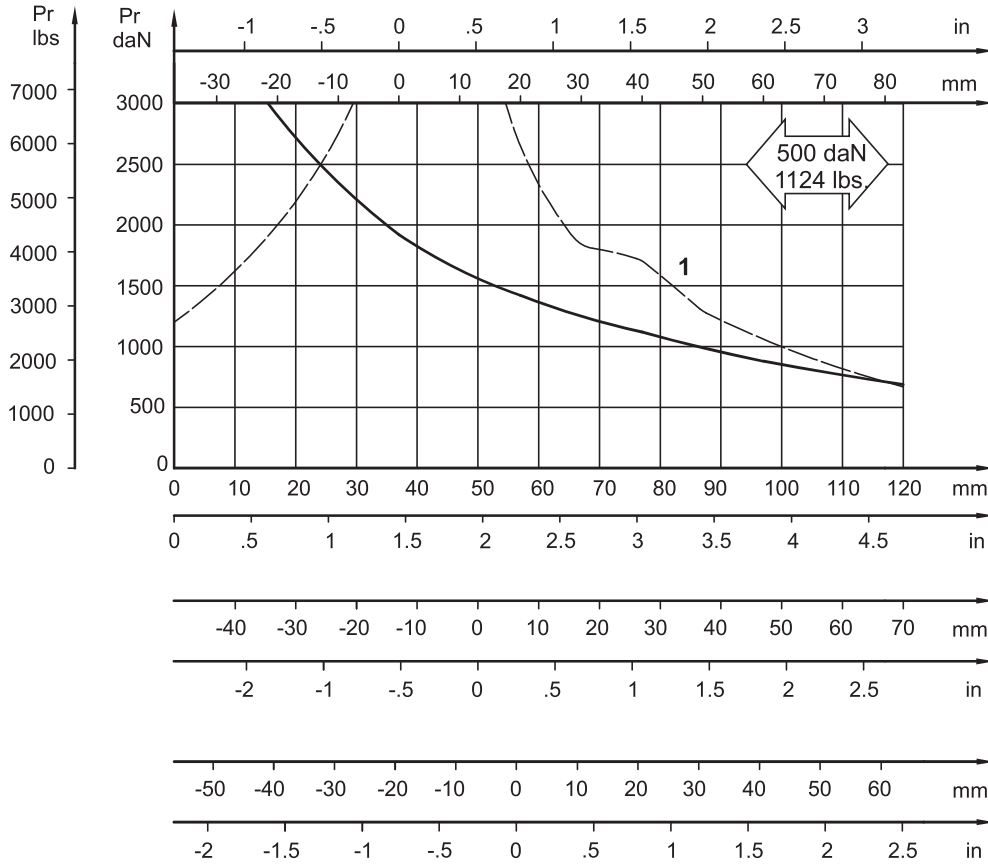

Mounting Flange:

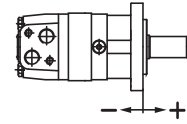

Standard
A-2
Magneto

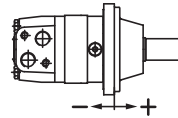

W - Wheel

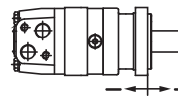

Q - Square

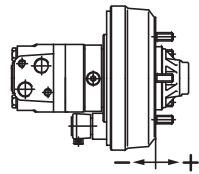

Drum Brake

Shaft: All type shafts except SA

FUNCTION DIAGRAM MSB

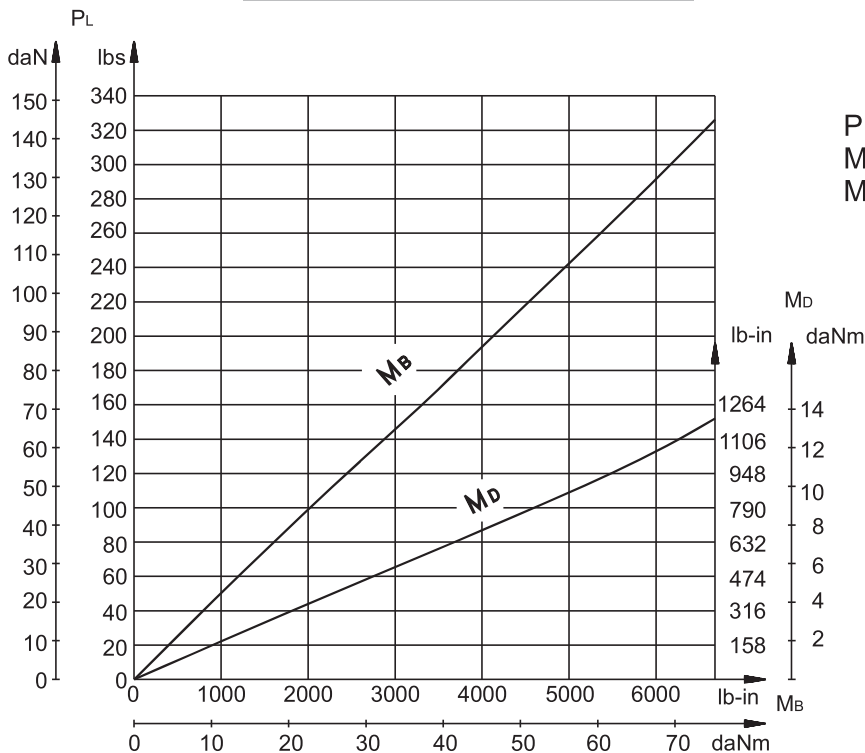

PL - Brake Lever Load
MB - Brake Torque
MD - Brake Lever Torque

DIMENSIONS AND MOUNTING DATA - MSS and MSV

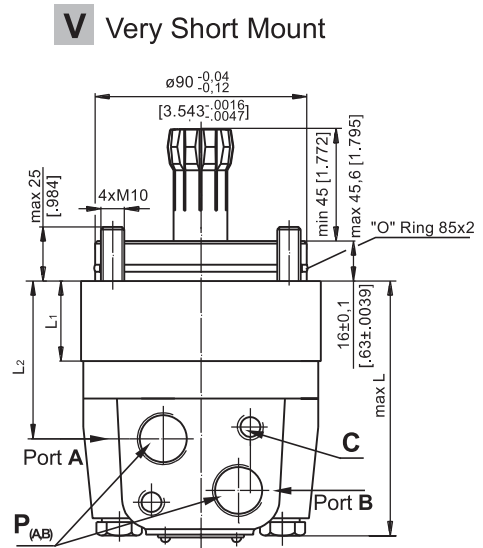
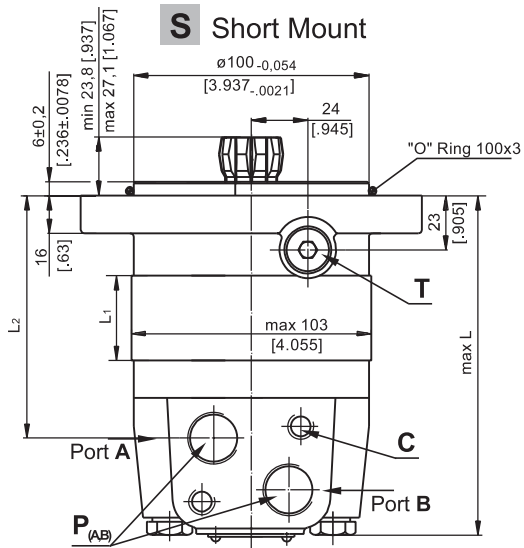

Port Dim.
See Page 16

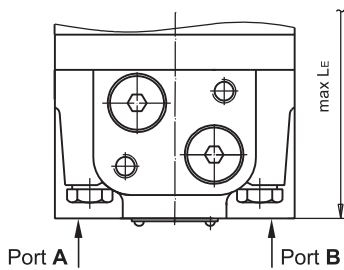
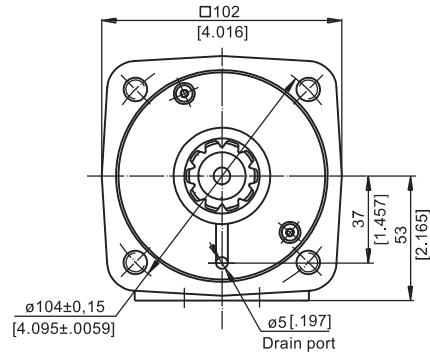
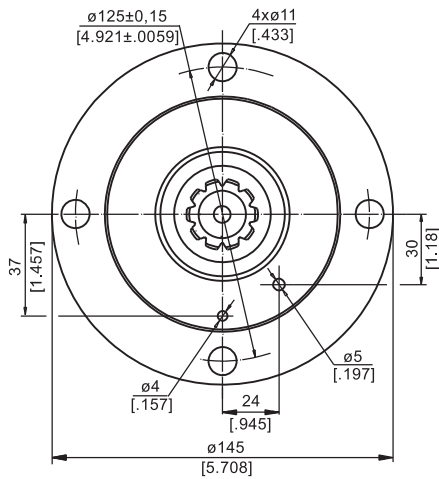

- C** : 2xM10 - 12 mm [.47 in] depth
- P_(A,B)** : 2xG1/2 or 2xM22x1,5 - 15 mm [.59 in] depth
- T** : G 1/4 or M14x1,5 - 12 mm [.47 in] depth (plugged)

Standard Rotation
Viewed from Shaft End
Port A Pressurized - **CW**
Port B Pressurized - **CCW**

Reverse Rotation
Viewed from Shaft End
Port A Pressurized - **CCW**
Port B Pressurized - **CW**

Type	L, mm [in]	L ₂ , mm [in]	*L _E , mm [in]	Type	L, mm [in]	L ₂ , mm [in]	*L _E , mm [in]	L ₁ , mm [in]
MSS 80	125 [4.92]	83 [3.27]	134 [5.28]	MSV 80	91 [3.58]	47 [1.85]	97 [3.82]	14,0 [.55]
MSS 100	129 [5.08]	87 [3.43]	138 [5.43]	MSV 100	94 [3.70]	50,5 [1.99]	100 [3.94]	17,4 [.69]
MSS 125	133 [5.24]	90 [3.54]	141 [5.55]	MSV 125	99 [3.90]	55 [2.17]	105 [4.13]	21,8 [.86]
MSS 160	139 [5.47]	96 [3.78]	147 [5.79]	MSV 160	105 [4.13]	61 [2.40]	111 [4.37]	27,8 [1.09]
MSS 200	146 [5.75]	103 [4.05]	154 [6.06]	MSV 200	112 [4.41]	68 [2.78]	118 [4.64]	34,8 [1.37]
MSS 250	155 [6.10]	112 [4.41]	163 [6.42]	MSV 250	120 [4.72]	76,5 [3.01]	126 [4.96]	43,5 [1.71]
MSS 315	166 [6.54]	123 [4.84]	174 [6.85]	MSV 315	132 [5.20]	88 [3.46]	138 [5.43]	54,8 [2.16]
MSS 400	181 [7.13]	138 [5.43]	189 [7.44]	MSV 400	146 [5.75]	103 [4.05]	153 [6.02]	69,4 [2.73]
MSS 475	194 [7.64]	152 [5.98]	203 [7.99]	MSV 475	160 [6.30]	116 [4.57]	166 [6.54]	82,6 [3.25]
MSS 525	186 [7.32]	144 [5.67]	195 [7.68]	MSV 525	152 [5.98]	108 [4.25]	158 [6.22]	74,5 [2.93]
MSS 565	192 [7.56]	150 [5.91]	201 [7.91]	MSV 565	158 [6.22]	114 [4.49]	164 [6.46]	80,2 [3.16]

* - For Rear Ported Motors.

DIMENSIONS AND MOUNTING DATA - MSU

U Ultra Short Mount

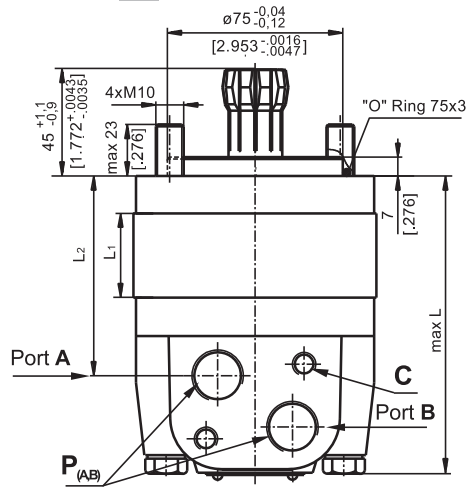

Port Dim.
See Page 16

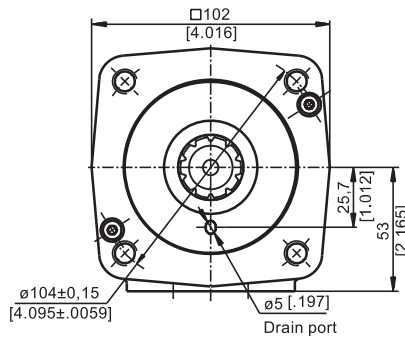

E Rear ports

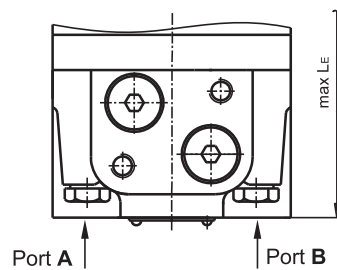

C : 2xM10-12 mm [.47 in] depth
P_(A,B): 2xG1/2 or 2xM22x1,5, 15 mm [.59 in] depth

Standard Rotation
 Viewed from Shaft End
 Port **A** Pressurized - **CW**
 Port **B** Pressurized - **CCW**

Reverse Rotation
 Viewed from Shaft End
 Port **A** Pressurized - **CCW**
 Port **B** Pressurized - **CW**

Type	L, mm[in]	L ₂ , mm[in]	*L _E , mm[in]	L ₁ , mm[in]
MSU 80	105,5 [4.15]	63 [2.48]	111,5 [4.39]	14,0 [.55]
MSU 100	109 [4.29]	66,5 [2.62]	115 [4.53]	17,4 [.69]
MSU 125	113 [4.45]	71 [2.80]	119 [4.69]	21,8 [.86]
MSU 160	119 [4.69]	77 [3.03]	125 [4.92]	27,8 [1.09]
MSU 200	126 [4.96]	84 [3.31]	132 [5.20]	34,8 [1.37]
MSU 250	135 [5.32]	92,5 [3.64]	141 [5.55]	43,5 [1.71]
MSU 315	146 [5.75]	104 [4.09]	152 [5.98]	54,8 [2.16]
MSU 400	160 [6.30]	119 [4.69]	167 [6.58]	69,4 [2.73]
MSU 475	174 [6.85]	132 [5.20]	180 [7.09]	82,6 [3.25]
MSU 525	166 [6.54]	124 [4.88]	172 [6.77]	74,5 [2.93]
MSU 565	172 [6.77]	130 [5.12]	178 [7.01]	80,2 [3.16]

* - For Rear Ported Motors.

DIMENSIONS OF THE ATTACHED COMPONENT

For MSS

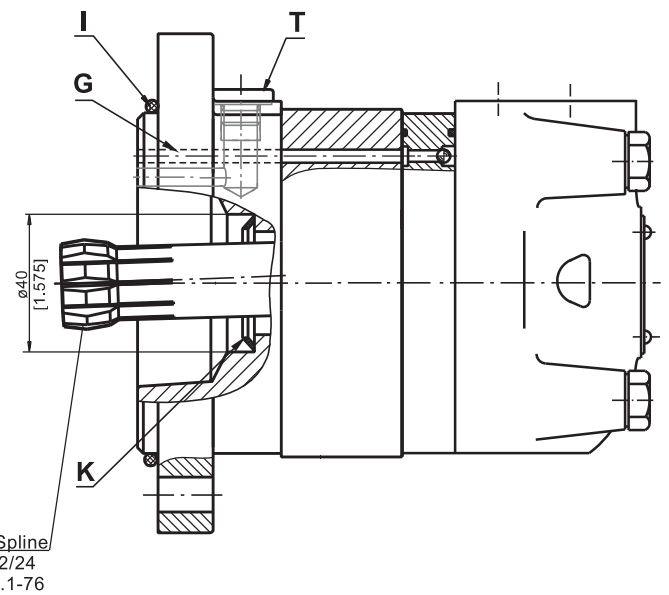
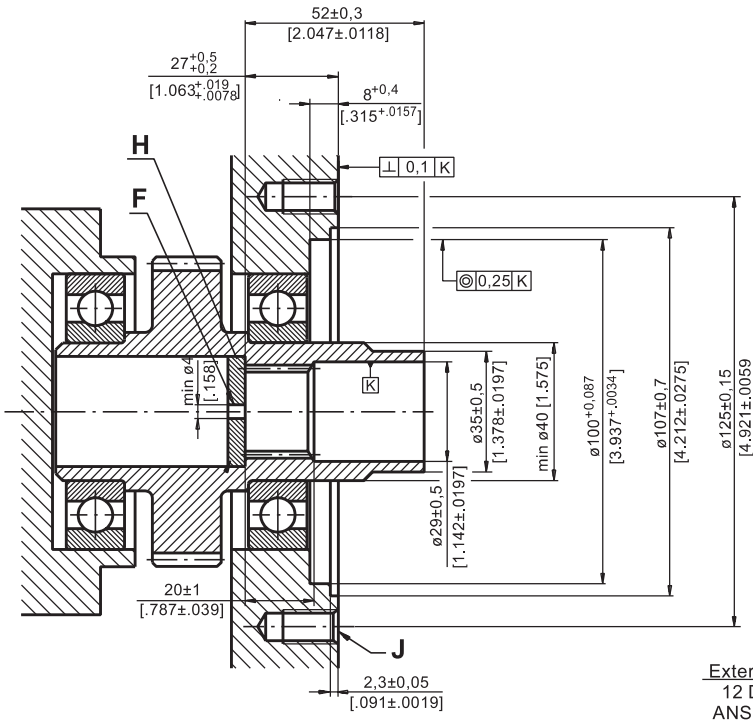

- F:** Oil circulation hole
- H:** Hardened stop plate
- J:** 4xM10 - 16 mm [.63 in] depth, 90°
- G:** Internal drain channel
- I:** O- Ring 100x3 mm [3.94x.12 in]
- K:** Conical seal ring
- T:** Drain connection G1/4 or M14x1,5

For MSV

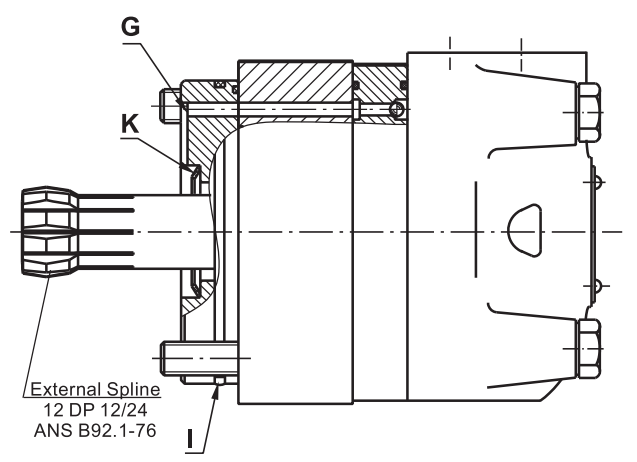
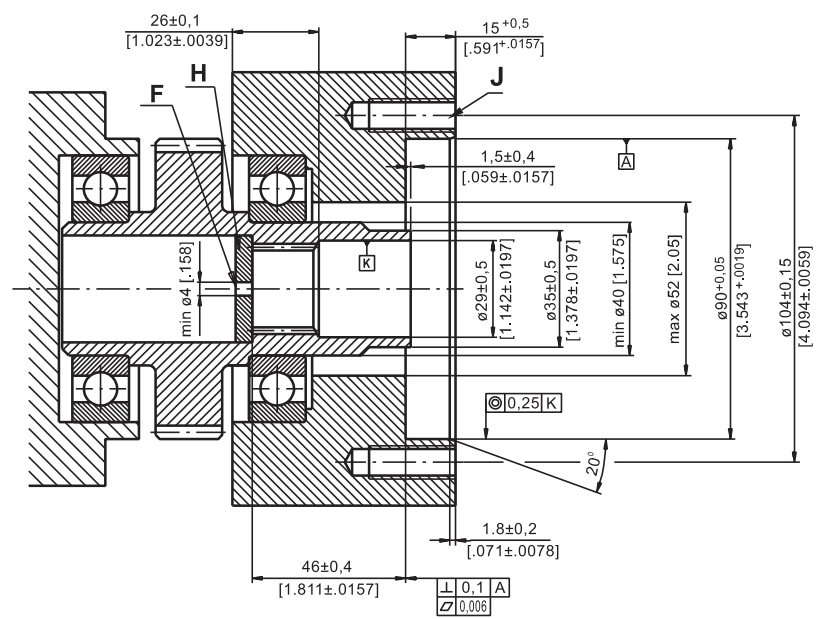

- F:** Oil circulation hole
- H:** Hardened stop plate
- J:** 4xM10 - 26 mm [1.024 in] depth, 90°
- G:** Internal drain channel
- I:** O- Ring 85x2 mm [3.346x.0787 in]
- K:** Conical seal ring



DIMENSIONS OF THE ATTACHED COMPONENT(continued)

For MSU

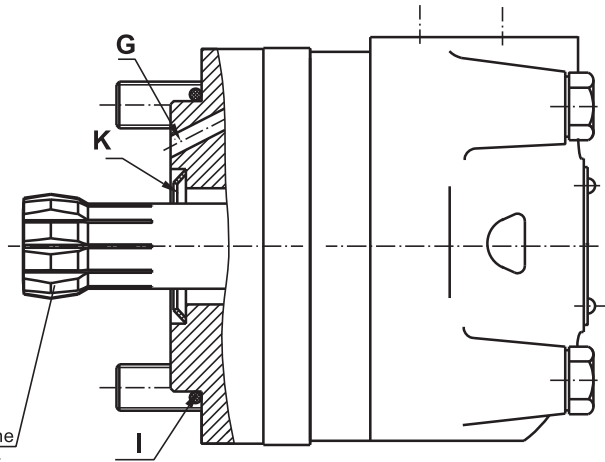
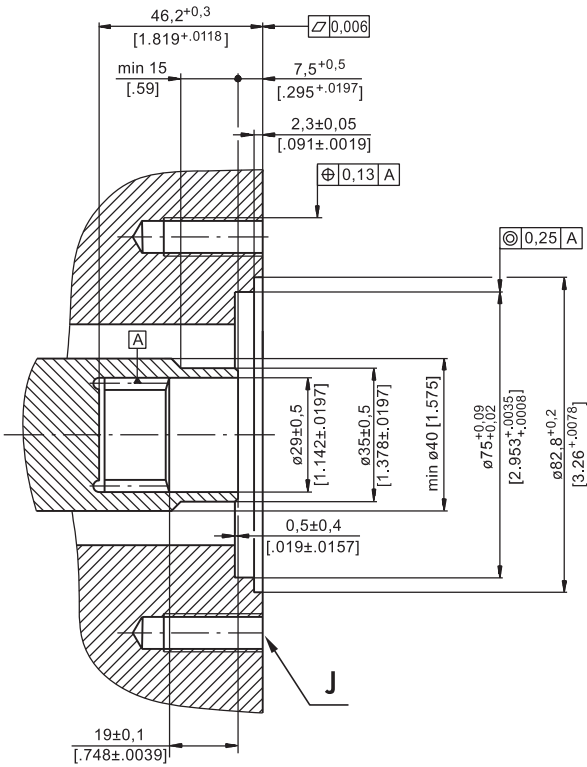

External Spline
12 DP 12/24
ANS B92.1-76

- J : 4xM10-26 mm [1.024 in] depth, 90°, ø104 [4.094]
- I : O- Ring 75x3 mm [2.952x.12 in]
- G: Internal drain channel
- K: Conical seal ring



DRAIN CONNECTION

The drain line has to be used when pressure in the return line can exceed the permissible pressure. It can be connected:

- For MSS at the drain port of the motor;
- For MSV and MSU at the drain connection of the attached component. The maximum pressure in the drain line is limited by the attached component and its shaft seal.

The drain line must be possible for oil to flow freely between motor and attached component and must be led to the tank. The maximum pressure in the drain line is limited by the attached component and its seal.

INTERNAL SPLINE DATA FOR THE ATTACHED COMPONENT

Standard ANS B92.1-1976, class 5
[m=2.1166; corrected x.m=+0,8]

Flat Root Side Fit	mm	inch
Number of Teeth	z 12	12
Diametral Pitch	DP 12/24	12/24
Pressure Angle	30°	30°
Pitch Dia.	D 25,4	1
Major Dia.	D _{ri} 28,0 _{-0,1}	1.1 ÷ 1.098
Minor Dia.	D _i 23,0 ^{+0,033}	.907 ÷ .905
Space Width [Circular]	L _o 4,308±0,020	.1704 ÷ .1688
Fillet Radius	R 0,2	.008
Max. Measurement between Pins	L 17,62 ^{+0,15}	.699 ÷ .694
Pin Dia.	d 4,835±0,001	.19039±.19031

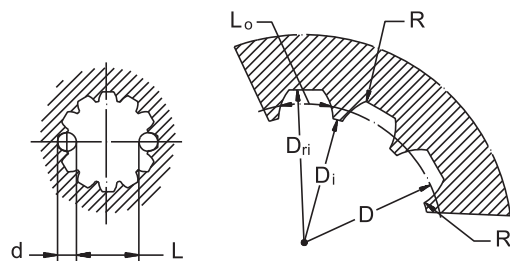

Hardening Specification:
 HV=750±50 on the surface
 HV=560 at 0,7±0,2 mm [.035±.019 in] case depth
 Material: 20 MoCr4 EN 10084 or better

ORDER CODE

	1	2	3	4	5	6	7	8	9
M S									

Pos.1 - Mounting Flange

omit - SAE A-4 mount, four holes

- A** - SAE A-2 mount, four holes
- F** - Magneto mount, four holes
- Q** - Square mount, four holes
- B** - Motor with drum brake
- S** - Short motor
- V** - Very short motor
- U** - Ultra short motor
- W** - Wheel mount

Pos.2 - Port type

omit - Side ports

- E** - Rear ports

Pos.3 - Displacement code

- 80** - 80,5 cm³/rev [4.91 in³/rev]
- 100** - 100,0 cm³/rev [6.10 in³/rev]
- 125** - 125,7 cm³/rev [7.67 in³/rev]
- 160** - 159,7 cm³/rev [9.74 in³/rev]
- 200** - 200,0 cm³/rev [12.20 in³/rev]
- 250** - 250,0 cm³/rev [15.30 in³/rev]
- 315** - 314,9 cm³/rev [19.20 in³/rev]
- 400** - 397,0 cm³/rev [24.20 in³/rev]
- 475** - 474,6 cm³/rev [28.96 in³/rev]
- 525** - 522,7 cm³/rev [31.88 in³/rev]
- 565** - 564,9 cm³/rev [34.47 in³/rev]

Pos.4 - Shaft Extensions*

omit - for **B, S, U** and **V** mounting flange

- C** - ø32 straight, Parallel key A10x8x45 DIN6885
- CO** - ø1¼" straight, Parallel key ⁵/₁₆"x⁵/₁₆"x1¼" BS46
- K** - ø35 tapered 1:10, Parallel key B6x6x20 DIN6885
- SL** - ø34,85 p.t.o. DIN 9611 Form 1
- SH** - ø1¼" splined 14T ANS B92.1-1970
- SA** - 7/8"-13T splined ANS B92.1-1970
- CA** - ø25 straight, Parallel key A8x7x32 DIN6885

Pos.5 - Shaft Seal Version (see page 16)

omit - Low pressure seal

- U** - High pressure sealkey A10x8x45 DIN6885

Pos.6 - Ports

omit - BSPP (ISO 228)

- M** - Metric (ISO 262)

Pos.7 - Actuating Direction**

- /R** - Right
- /L** - Left

Pos.8 - Special Features (see page 51)

Pos.9 - Design Series

omit - Factory specified

NOTES: The following combinations are not allowed: - **Q** flange with "**CO**", "**CA**" and "**SA**" shafts.

* The permissible output torque for shafts must not be exceeded!

** For MSB only!

The hydraulic motors are mangano-phosphatized as standard.